

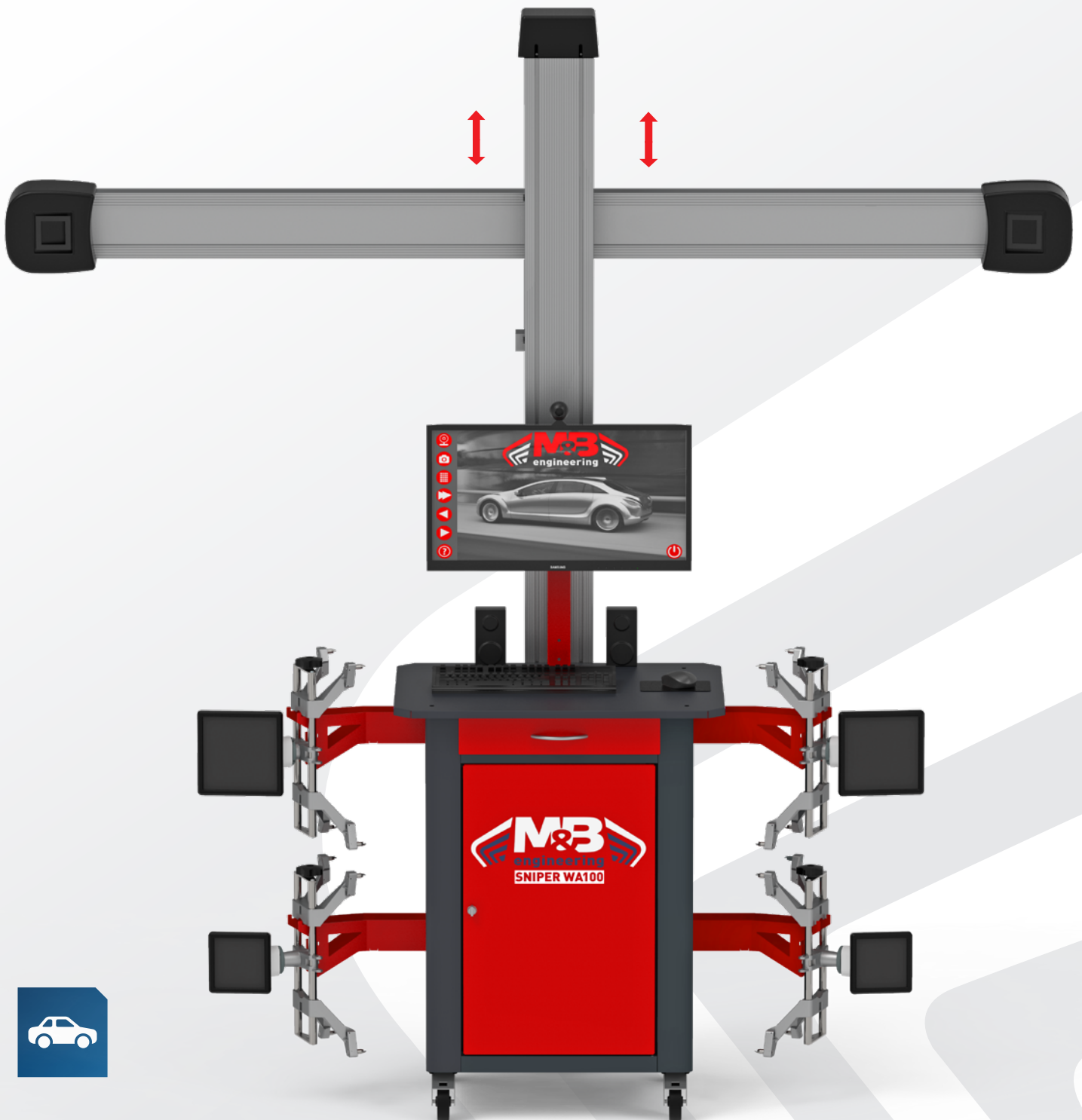

SNIPER WA100

3D HD WHEEL ALIGNMENT FOR MAXIMUM PRECISION





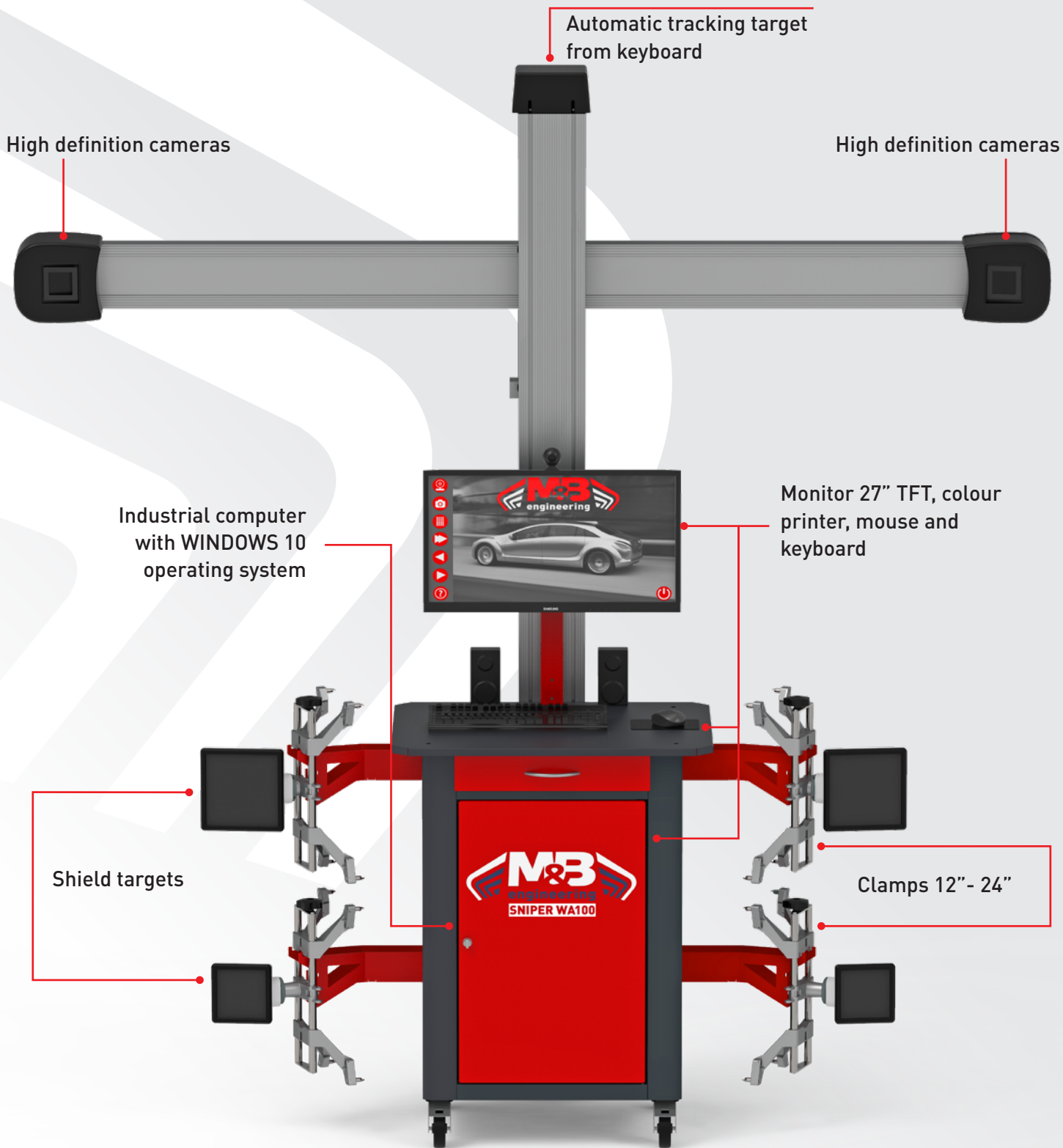

SNIPER WA100 3D HD WHEEL ALIGNMENT FOR MAXIMUM PRECISION

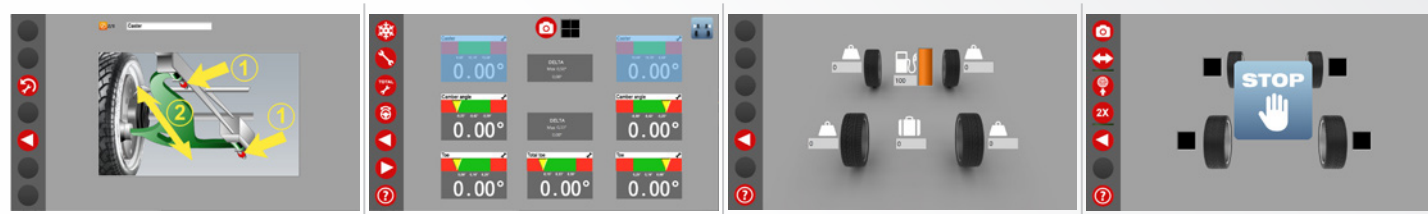





User friendly interface







DURABLE TARGETS

-  **Targets with reduced dimensions;** no electronic components
-  **Bersagli di dimensioni ridotte;** nessun componente elettronico
-  **Cibles compactes;** pas de composants électroniques
-  **Kompakte Zielscheiben;** Keine elektronischen Komponenten
-  **Objetivos compactos;** ningun componentes electrónicos



-  **M&B SNIPER WA100** high-precision 3D wheel aligner, designed to ensure real-time reliable results thanks to fast and intuitive automation
-  **M&B SNIPER WA100** è l'assetto ruote 3D di alta precisione, studiato per garantire risultati affidabili in tempo reale grazie ad un'automazione rapida e intuitiva
-  **M&B SNIPER WA100** est l'alignement des roues 3D haute précision, imaginée pour garantir des résultats fiables en temps réel grâce à une automatisation rapide et intuitive
-  **M&B SNIPER WA100** ist eine hochpräzise 3D-Achsmessgerät, die dank einer schnellen und intuitiven Automatisierung zuverlässige Ergebnisse in Echtzeit gewährleistet
-  **M&B SNIPER WA100** es el alineamiento ruedas 3D de precisión elevada, estudiado para garantizar resultados de confianza en tiempo real gracias a una automatización rápida e intuitiva

-  **Mobile cameras: automatic adjustment** in the correct position according to the lift height
Full performance with wheelbase, track and diagonal, wheel diameter, caster angle and friction range measurements
Measurements with 2 targets for long vehicles
Single raised wheel run-out: useful in small spaces
Identification of driving problems, resulting from measures not contemplated in the specifications
User-friendly interface: using it and printing the final report are quick and easy
-  **Telecamere mobili: regolazione automatica** nella posizione corretta in base all'altezza del ponte
Prestazioni complete con misure di passo, carreggiata, diagonali, diametro ruote, braccio a terra e raggio d'attrito
Misura con 2 targets in caso di veicoli lunghi
Run-out a ruota singola sollevata: utile in mancanza di spazio
Diagnosi dei disturbi di guida conseguenti a misure rilevate fuori specifica
Interfaccia intuitiva: l'utilizzo e la stampa del report finale sono facili e veloci
-  **Caméras mobiles : réglage automatique** dans la position correcte en fonction de la hauteur du l'élévateur
Performances complètes avec mesures de pas, largeur et diagonales, du diamètre des roues, de bras à terre et rayon de frottement
Mesure avec 2 cibles pour les véhicules longs
Mesure de l'excentricité à roue indépendante soulevée utile en manque d'espace
Diagnostic des problèmes de conduite à la suite de mesures hors spécification
Interface intuitive : l'utilisation ainsi que l'impression du rapport final sont rapides et faciles
-  **Mobile Kameras: Automatische Einstellung** in der richtigen Position auf der Grundlage der Brückenhöhe
Volle Leistungen mit Messung von Radstand, Spurweite und Diagonalen, des Raddurchmessers, von Caster und Reibungsradius
Messung mit 2 Zielscheiben für lange Fahrzeuge
Run-out am einzelnen angehobenen Rad nützlich bei Platzmangel
Die Diagnose der Fahrstörungen infolge von Messungen außerhalb der Toleranz
Intuitive Benutzeroberfläche: Die Verwendung und das Drucken des Abschlussberichts sind schnell und einfach
-  **Telecámaras móviles: ajuste automático** en posición correcta de acuerdo con la altura del elevador
Prestaciones completas con medida de paso, superficie de rodadura, diagonales, del diámetro de las ruedas, de brazo en el suelo y radio de rozamiento
Medida con 2 puntos de referencia en vehículos largos
Desviación con una rueda levantada útil si falta espacio
Diagnóstico de problemas de conducción debidos a medidas que no cumplen las especificaciones
Interfaz intuitiva: el uso y la impresión del informe final son rápidos y fáciles

STANDARD CONFIGURATION



OPTIONAL ACCESSORIES

<p>2 premium turnplates 1,0T with paddles for car (in replacement of the standard ones)</p>	<p>Camera support for the positioning of the vehicle on the lift</p>	<p>Kit of 16 extensions for 4-point clamps 12"- 24" with 3" extension clamping range</p>	<p>Monitor 43" (in replacement to the standard one)</p>
<p>Mobile trolley kit to provide full mobility to both cabinet and beam</p>	<p>Calibration Kit complete with HD targets and spirit level to calibrate the cameras</p>	<p>Pair of rear swinging platforms</p>	<p>Car databank update</p>

OVERALL DIMENSIONS AND INSTALLATION PLAN

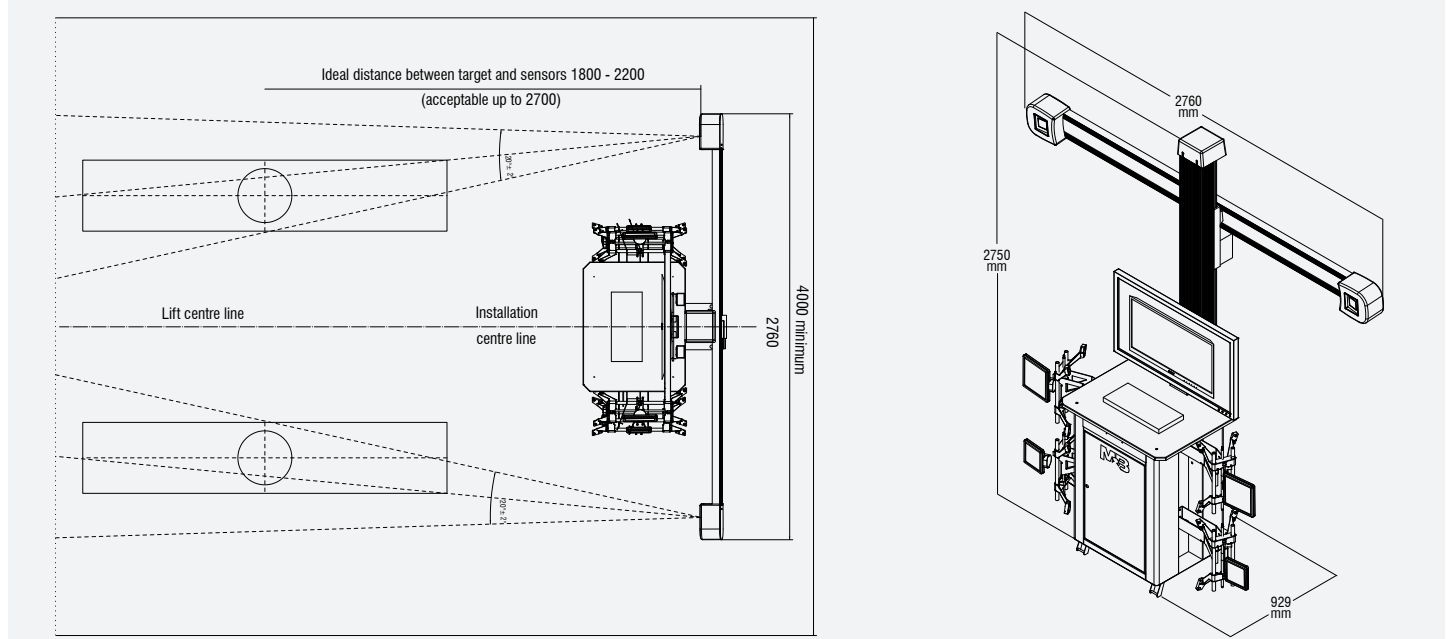

M&B ENGINEERING SRL
Via Nobel, 21 - 42124 Reggio Emilia (RE)
info@mb-re.it - www.mbenengineering.info